



## 2020 WENDEL ROAD

KRISTA M. BENNETT, REALTOR®; GRI | CELL: 830-998-0633



# FREDERICKSBURG REALTY TEXAS RANCH REALTY

**2020 Wendel Rd. | Harper, Texas 78631 | Gillespie County**

**174.85+/- Acres**

**\$2,250,000**

## **Agent**

Krista Bennett

## **Property Highlights**

- **174.8± acres** in Gillespie County
- Minutes to Harper
- Close proximity to **Hwy 290 and I-10**
- 3-bed/2-bath brick home (approx. 2,145± sq ft)
- Barn, metal shop & livestock working pens
- Smoke room & dedicated meat room
- Improvements located directly off paved county road
- Remainder of acreage open and highly usable
- Fenced and cross-fenced
- Ideal for cattle, goats, horses, or mixed-use ranching
- Ag exempt

## **Property Taxes:**

\$990.37 Ag Exempt, HS, Over 65

\$18,420.58 w/o Exemptions

## **Ad and MLS Copy**

Positioned in Harper with convenient access to Hwy 290 and I-10, this 174.8± acre Gillespie County ranch offers a rare combination of production capability, accessibility, and long-term flexibility.

The property features gently rolling native pasture with scattered hardwoods and open grazing areas well suited for livestock operations. Well-maintained fencing and working pens support active ranch use, while the terrain provides both functional grazing land and expansive Hill Country views.

All improvements are strategically located directly off a paved county road, allowing the majority of the acreage to remain uninterrupted and highly usable. The ranch includes a traditional brick single-family home offering a 3-bedroom, 2-bath configuration with approximately 2,145± square feet of living space. Additional improvements include a 384± sq ft metal shop, a 1,650± sq ft barn, a smoke room and dedicated meat processing room, along with livestock pens and working facilities designed for efficient ranch operations.

The infrastructure supports cattle, goats, or diversified agricultural use, and the current ag exemption helps keep annual carrying costs low.

Because the improvements are positioned near the road frontage, the property layout offers flexibility for a future owner who may wish to maintain the ranch as a whole or explore thoughtful division while preserving the integrity of the land.

Located within easy reach of Fredericksburg, Kerrville, and I-10, this ranch offers excellent regional accessibility while maintaining the privacy and quiet setting characteristic of western Gillespie County.

This versatile working ranch offers established infrastructure, scenic Hill Country terrain, and a long-term investment potential.

MLS #: A101869A (Active) List Price: \$2,250,000 (37 Hits)

2020 -- Wendel Rd Harper, TX 78



**Type:** Ranch Land, Single Family Residential  
**Best Use:** Grazing, Residential, Recreational  
**Topography:** Rolling Slope, Wooded, Open, Views  
**Surface Cover:** Wooded/Native Pasture  
**Views:** Yes  
**Apx \$/Acre:** 0  
**Lot/Tract #:**

**Original List Price:** \$2,250,000  
**Area:** County-West  
**Subdivision:** N/A  
**County:** Gillespie  
**School District:** Harper  
**Distance From City:** Less than 6 mile  
**Property Size Range:** 101-250 Acres  
**Apx Acreage:** 174.8500  
**Seller's Est Tax:** 990.37  
**Showing Instructions:** Call Listing Agent  
Lockbox, Gate Locked-Combo  
**Days on Market** 6

**Tax Exemptions:** Taxes w/o Exemptions: \$18,420.58 **Tax Info Source:** CAD **CAD Property ID #:** 38487, 8467, 5863 **Zoning:**

**Flood Plain:** No **Deed Restrictions:** No **Easements:** Electric Service **Road Maintenance Agreement:** No

**HOA:** No **HOA Fees:** **HOA Fees Pd:**

**Items Not In Sale:** Cooler, meat processing equipment

**Documents on File:** Topographical Map, Aerial Photo

**Water:** Well  
**Sewer:** Septic Tank  
**Utilities:** CTEC Electric on Property  
**Access/Location:** County Road, Private  
**Minerals:** Unknown

**Improvements:** Barn, House, Storage Building, Workshop, W Pens  
**Misc Search:** Livestock Permitted  
**Fence:** Cross Fenced, Perimeter

**TrmsFin:** Cash, Conventional **Possessn:** Closing/Funding **Excl Agy:** No

**Title Company:** Hill Country Title **Attorney:** **Refer to MLS#:**

**Location/Directions:** From Harper head West on Hwy 290, approx 1.7miles, turn R onto Wendel Rd. Continue on Wendel Rd for 2 mi. Property will be directly ahead, at the first 90.

**Owner:** Marian Strackbein

**Legal Description:** ABS A0964 M E P & P RR CO #368, 69.1 ACRES ,ABS A1647 G F HARPER #418, 105.45 ACRES , ABS A1647 G F H #418, 0.25 ACRES, -HOMESITE-

**Instructions:** Call listing agent - 24hr preferred, but not required

**Public Remarks:** Positioned just outside Harper with convenient access to Hwy 290 and I-10, this 174.8± acre Gillespie County ranch offers a rare combination of production capability, accessibility, and long-term flexibility. The property features gently rolling native pasture with scattered hardwoods and open grazing areas well suited for livestock operations. Well-maintained fencing and working pens support ranch use, while the terrain provides both functional grazing land and expansive Hill Country views. All improvements are strategically located directly off a paved county road, allowing the majority of the acreage to remain uninterrupted and highly usable. The ranch includes a traditional brick single-family home offering a 3-bedroom, 2-bath configuration with approximately 2,145± square feet of living space. Additional improvements include a detached garage/shop, a 1,650± sq ft barn with workshop, a smoke room and dedicated meat processing room, along with livestock pens and working facilities designed for efficient ranch operations. The infrastructure supports goats, or diversified agricultural use, and the current ag exemption helps keep annual carrying costs low. Located within easy reach of Fredericksburg, Kerrville, and I-10, this ranch offers excellent regional accessibility while maintaining the privacy and quiet setting characteristic of western Gillespie County.

**Agent Remarks:** Cooler & meat processing equipment do NOT stay.

**Withdraw Comments:**

**Display on Internet:** Yes **Display Address:** Yes **Allow AVM:** No **Allow Comments:** No

**Office Broker's Lic #:** 9003085

**Listing Office:** Fredericksburg Realty (#:14)  
**Main:** (830) 997-6531  
**Mail Address 1:** 257 W Main Street  
**Mail City:** Fredericksburg  
**Mail Zip Code:** 78624  
**Supervising Agent Name:**  
**Supervising Agent License #:**

**Listing Agent:** Krista Bennett (#:127)  
**Agent Email:** [krista@fredericksburgrealty.com](mailto:krista@fredericksburgrealty.com)  
**Contact #:** (830) 998-0633  
**License Number:** 0622568

Information Herein Deemed Reliable but Not Guaranteed  
Central Hill Country Board of REALTORS Inc., 2007



APPLICATION FOR PRIVATE SEWAGE SYSTEM  
CONSTRUCTION PERMIT AND LICENSE

DATE 9-29-89 PERMIT NO. 1529 FEE \$ 150.00

I, hereby make an application for a license to construct and operate a private sewage disposal system in Gillespie County, Texas.

OWNER Kermit Stackbein PHONE NO. (512) 295-3878

MAILING ADDRESS 103 Lambs Trail Buda, Texas 78610 ✓

HOUSE NO. AND STREET ADDRESS 2020 Wendel Rd

SUBDIVISION, DESCRIBED LOCATION OR ATTACH A MAP/SKETCH

NAME Wendel Rd 2mi. Right Name on Gate

SIZE ACREAGE OR TRACT 175 ACRES SECTION \_\_\_\_\_ BLOCK \_\_\_\_\_ LOT \_\_\_\_\_

DESCRIPTION OF STRUCTURE TO BE SERVED

House ( ) Mobile Home (X) Other \_\_\_\_\_

Commercial \_\_\_\_\_

(Type of Business)

Living Area ( ) Bedrooms ( 2 ) Bathrooms ( 1 ) Disposal ( )

Washing Machine ( ✓ ) Dishwasher ( ) Water Softener ( ) Other \_\_\_\_\_

Water Supply By: Public System ( ) Community ( ) Individual ( X )

DATE 9-29-89 INSPECTOR-SANITARIAN Dave Baxton

Authorization is hereby given to the Private Sewage Facility, Gillespie County, Texas, Texas Department of Water Resources, the Texas State Department of Health Resources, or their agents or designees, singly or jointly, to enter upon the above described property for the purpose of making soil percolation tests, inspecting sewage systems, or for any reason consistent with the water quality program of the Texas Department of Water Resources, the Texas State Department of Health Resources and the Private Sewage Facility, Gillespie County, Texas.

(If signed by Owner, Authorized Agent, Contractor, provide name, address and phone #)

DATE 9-29-89 Kermit Stackbein

Signature of Owner or Authorized Agent

Authorization to proceed with construction will be provided after a joint (Owner or Installer and Inspector for the Private Sewage Facility, Gillespie County, Texas survey of the proposed site for the facility and analysis of percolation test data) (If Required)

THIS PERMIT TO CONSTRUCT IS VALID FOR 180 DAYS.  
OFFICIAL USE ONLY

SITE INSPECTION OR PERCOLATION TEST

DATE \_\_\_\_\_ PERMIT NO. \_\_\_\_\_ FEE \_\_\_\_\_

TYPE SOIL - Rocky ( ) Gravel ( ) Sand ( ) Other \_\_\_\_\_

SLOPE - Flat ( ) Sloping ( ) Other \_\_\_\_\_

PERCOLATION TEST RESULTS INCHES FALL/20 MINUTES

HOLES (1) \_\_\_\_\_ (2) \_\_\_\_\_ (3) \_\_\_\_\_ (4) \_\_\_\_\_ (5) \_\_\_\_\_ (6) \_\_\_\_\_

(7) \_\_\_\_\_ (8) \_\_\_\_\_ PERC. TEST AVERAGE Per. 2 USDA.

DATE 10-12-89 INSPECTOR-SANITARIAN Dave Baxton

COMMENTS:

Site Inspection Revealed:

0" to 14" Cobbly Clay

14" to 21" Fractured Lime Stone

1000 Divided Tank  
550 sqft D.F.

CERTIFICATION OF APPROVAL

FINAL INSPECTION

DATE 10-12-89 PERMIT NO. 1529 FEE 60<sup>00</sup>  
MANUFACTURER Wilbert Vault  
TANK #1 SN# 10-2-89 TANK #2 SN# N/A  
SIZE TANK #1 1000 GAL <sup>Divided</sup> TANK #2 N/A TYPE Concrete  
ABSORPTION TRENCH ( ) LENGTH \_\_\_\_\_ WIDTH \_\_\_\_\_  
ABSORPTION BED AREA (  ) SQUARE FEET 625 sqft  
COMMERCIAL ( ) PRIVATE RESIDENCE (  )  
INSTALLER OR CONTRACTOR Harry Wilke  
ADDRESS HC 64 Box 420 Harper TX 78631 PHONE # 864-4575  
DATE 10-13-89 FINAL INSPECTION MADE BY Dave Benson

(INSPECTION IS REQUIRED AFTER TANK AND PIPES ARE INSTALLED, BUT NOT COVERED)  
MAKE A SKETCH OF SYSTEM  
(NOT TO SCALE)

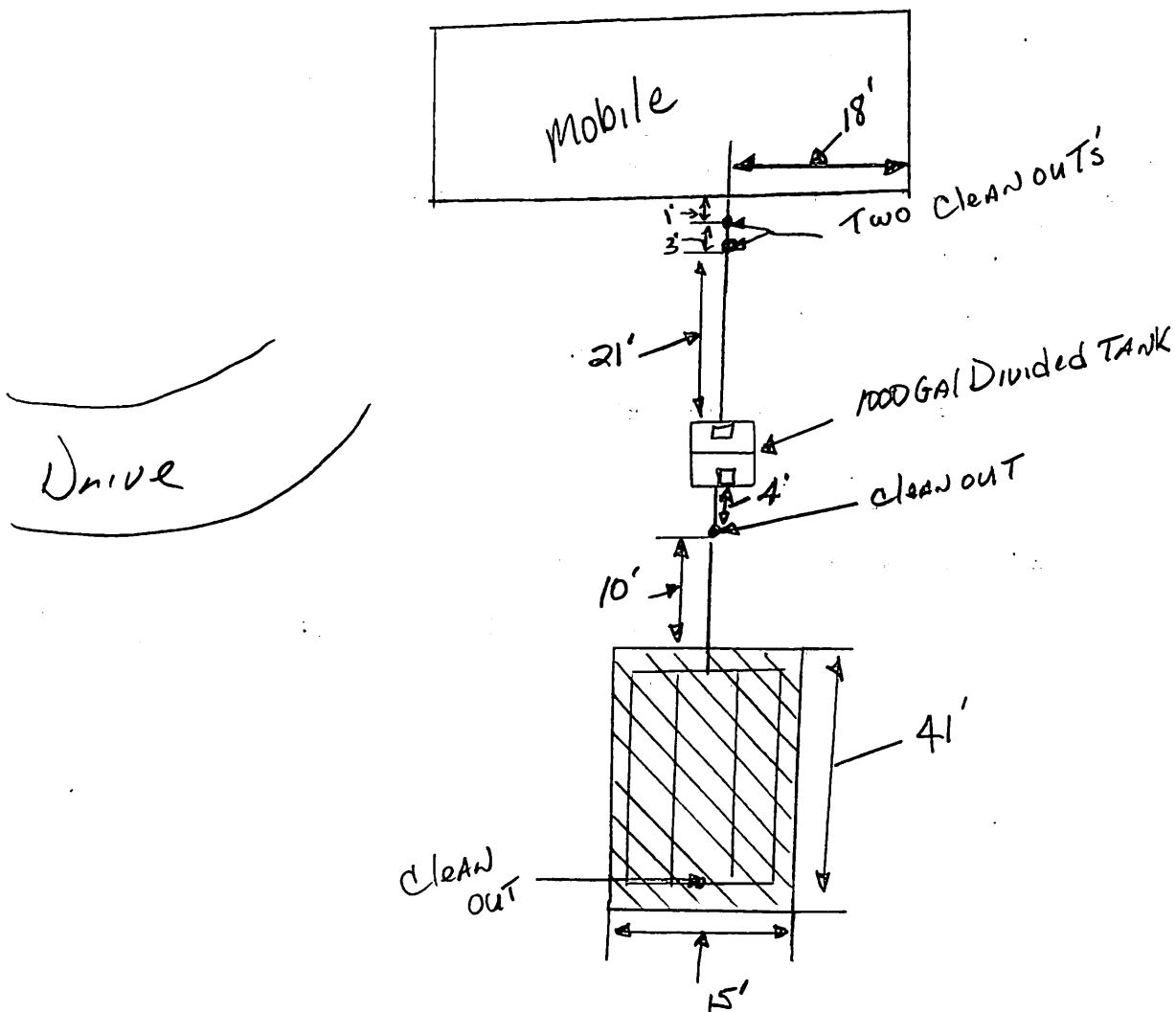

# Gillespie CAD Property Search

## Property ID: 38487 For Year 2025

### Property Details

Account		
Property ID:	38487	Geographic ID: A1647-0418-000000-00
Type:	R	Zoning:
Property Use:		Condo:
Location		
Situs Address:	2020 WENDEL RD TX	
Map ID:	5-A	Mapsco:
Legal Description:	ABS A1647 G F HARPER #418, 105.45 ACRES	
Abstract/Subdivision:	A1647	
Neighborhood:	(H200) HARPER NORTH	
Owner		
Owner ID:	349489	
Name:	STRACKBEIN, MARIAN G	
Agent:		
Mailing Address:	2020 WENDEL HARPER, TX 78631	
% Ownership:	100.0%	
Exemptions:	For privacy reasons not all exemptions are shown online.	

### Property Values

Improvement Homesite Value:	\$0 (+)
-----------------------------	---------

<b>Improvement Non-Homesite Value:</b>	\$17,090 (+)
<b>Land Homesite Value:</b>	\$0 (+)
<b>Land Non-Homesite Value:</b>	\$0 (+)
<b>Agricultural Market Valuation:</b>	\$891,100 (+)
<b>Market Value:</b>	\$908,190 (=)
<b>Agricultural Value Loss:</b>	\$879,460 (-)
<b>Appraised Value:</b>	\$28,730 (=)
<b>HS Cap Loss:</b>	\$0 (-)
<b>Circuit Breaker:</b>	\$0 (-)
<b>Assessed Value:</b>	\$28,730
<b>Ag Use Value:</b>	\$11,640

Information provided for research purposes only, for current ownership research you are able to change the search year to 2026. Legal descriptions and acreage amounts are for Appraisal District use only and should be verified prior to using for legal purpose and or documents. Please contact the Appraisal District to verify all information for accuracy.

## Property Taxing Jurisdiction

**Owner:** STRACKBEIN, MARIAN G

Entity	Description	Market Value	Taxable Value	Estimated Tax	Freeze Ceiling
G086	GILLESPIE COUNTY	\$908,190	\$28,730	\$77.14	
HUW	HILL CNTRY UWCD	\$908,190	\$28,730	\$1.41	
SHP	HARPER ISD	\$908,190	\$28,730	\$191.60	
WCD	GILLESPIE WCID	\$908,190	\$28,730	\$0.05	

CAD	GILLESPIE CENTRAL APPRAISAL DISTRICT	\$908,190	\$28,730	\$0.00	
-----	--------------------------------------	-----------	----------	--------	--

**Total Tax Rate:** 0.940478

**Estimated Taxes With Exemptions:** \$270.20

**Estimated Taxes Without Exemptions:** \$8,541.33

## Property Improvement - Building

**Type:** MISC IMP **Living Area:** 0 sqft **Value:** \$17,090

Type	Description	Class CD	Year Built	SQFT
BLDG	BUILDING	*	2004	384
BARN	BARN	*	1987	1650
CP	CARPORT	*	2004	640

## Property Land

Type	Description	Acreage	Sqft	Eff Front	Eff Depth	Market Value	Prod. Value
RN2	NATIVE PASTURE 2	55.45	2,415,402.00	0.00	0.00	\$468,580	\$6,210
RN3	NATIVE PASTURE 3	43.00	1,873,080.00	0.00	0.00	\$363,370	\$4,620
RID2	IMPROVED PASTURE 2	7.00	304,920.00	0.00	0.00	\$59,150	\$810

## Property Roll Value History

Year	Improvements	Land Market	Ag Valuation	Appraised	HS Cap Loss	Assessed
2025	\$17,090	\$891,100	\$11,640	\$28,730	\$0	\$28,730
2024	\$17,090	\$891,100	\$10,790	\$27,880	\$0	\$27,880
2023	\$17,090	\$891,100	\$10,800	\$27,890	\$0	\$27,890
2022	\$17,090	\$790,880	\$10,060	\$27,150	\$0	\$27,150

2021	\$17,090	\$527,250	\$9,990	\$27,080	\$0	\$27,080
2020	\$17,090	\$461,440	\$8,270	\$25,360	\$0	\$25,360
2019	\$17,090	\$461,440	\$8,270	\$25,360	\$0	\$25,360
2018	\$17,090	\$461,440	\$7,840	\$24,930	\$0	\$24,930
2017	\$17,090	\$456,140	\$7,720	\$24,810	\$0	\$24,810

## Property Deed History

Deed Date	Type	Description	Grantor	Grantee	Volume	Page	Number
9/29/2022	TOD	TRANSFER ON DEATH	STRACKBEIN, KERMIT R	STRACKBEIN, MARIAN G	20226461		

## ARB Data

Hearing Date And Time	Board Members	Owner's Opinion Of Value	Board's Determination Of Value	ARB Determination
-----------------------	---------------	--------------------------	--------------------------------	-------------------

## Estimated Tax Due

If Paid: 02/25/2026 

Year	Taxing Jurisdiction	Tax Rate	Market Value	Taxable Value	Base Tax	Base Taxes Paid	Base Tax Due	Discount/Penalty & Interest
2025	GILLESPIE COUNTY	0.268500	\$908,190	\$28,730	\$77.14	\$77.14	\$0.00	\$0.00
2025	HILL CENTRY UWCD	0.004900	\$908,190	\$28,730	\$1.41	\$1.41	\$0.00	\$0.00
2025	HARPER ISD	0.666900	\$908,190	\$28,730	\$191.60	\$191.60	\$0.00	\$0.00
2025	GILLESPIE WCID	0.000178	\$908,190	\$28,730	\$0.05	\$0.05	\$0.00	\$0.00

# Gillespie CAD Property Search

## Property ID: 58630 For Year 2025

---

### Property Details

Account		
Property ID:	58630	Geographic ID: A1647-0418-000000-00
Type:	R	Zoning:
Property Use:		Condo:
Location		
Situs Address:	2020 WENDEL RD TX	
Map ID:	5-A	Mapsco:
Legal Description:	ABS A1647 G F HARPER #418, 0.25 ACRES, -HOMESITE-	
Abstract/Subdivision:	A1647	
Neighborhood:	(H200) HARPER NORTH	
Owner		
Owner ID:	349489	
Name:	STRACKBEIN, MARIAN G	
Agent:		
Mailing Address:	2020 WENDEL HARPER, TX 78631	
% Ownership:	100.0%	
Exemptions:	HS - For privacy reasons not all exemptions are shown online.	

---

### Property Values

--

<b>Improvement Homesite Value:</b>	\$464,410 (+)
<b>Improvement Non-Homesite Value:</b>	\$0 (+)
<b>Land Homesite Value:</b>	\$2,110 (+)
<b>Land Non-Homesite Value:</b>	\$0 (+)
<b>Agricultural Market Valuation:</b>	\$0 (+)
<b>Market Value:</b>	\$466,520 (=)
<b>Agricultural Value Loss:</b>	\$0 (-)
<b>Appraised Value:</b>	\$466,520 (=)
<b>HS Cap Loss:</b>	\$0 (-)
<b>Circuit Breaker:</b>	\$0 (-)
<b>Assessed Value:</b>	\$466,520
<b>Ag Use Value:</b>	\$0

Information provided for research purposes only, for current ownership research you are able to change the search year to 2026. Legal descriptions and acreage amounts are for Appraisal District use only and should be verified prior to using for legal purpose and or documents. Please contact the Appraisal District to verify all information for accuracy.

## Property Taxing Jurisdiction

**Owner:** STRACKBEIN, MARIAN G

Entity	Description	Market Value	Taxable Value	Estimated Tax	Freeze Ceiling
G086	GILLESPIE COUNTY	\$466,520	\$466,520	\$1,252.61	\$622.46
HUW	HILL CNTRY UWCD	\$466,520	\$466,520	\$22.86	
SHP	HARPER ISD	\$466,520	\$266,520	\$1,777.42	\$0.00

WCD	GILLESPIE WCID	\$466,520	\$466,520	\$0.83	
CAD	GILLESPIE CENTRAL APPRAISAL DISTRICT	\$466,520	\$466,520	\$0.00	

**Total Tax Rate:** 0.940478

**Estimated Taxes With Exemptions:** \$646.15

**Estimated Taxes Without Exemptions:** \$4,387.52

## Property Improvement - Building

**Type:** RESIDENTIAL **Living Area:** 2145.0 sqft **Value:** \$464,410

Type	Description	Class CD	Year Built	SQFT
MA	MAIN AREA	M5P	2005	2145
AGU2	ATT GARAGE UNFIN DOUBLE	M5P	2005	500
OP	OPEN PORCH	M5P	2005	520
OP	OPEN PORCH	M5P	2005	390
BLDG	BUILDING	*	2005	720

## Property Land

Type	Description	Acreage	Sqft	Eff Front	Eff Depth	Market Value	Prod. Value
RN2	NATIVE PASTURE 2	0.25	10,890.00	0.00	0.00	\$2,110	\$0

## Property Roll Value History

Year	Improvements	Land Market	Ag Valuation	Appraised	HS Cap Loss	Assessed
2025	\$464,410	\$2,110	\$0	\$466,520	\$0	\$466,520
2024	\$464,410	\$2,110	\$0	\$466,520	\$0	\$466,520
2023	\$464,410	\$2,110	\$0	\$466,520	\$26,957	\$439,563
2022	\$402,870	\$1,880	\$0	\$404,750	\$5,147	\$399,603

2021	\$365,810	\$1,250	\$0	\$367,060	\$3,785	\$363,275
2020	\$329,160	\$1,090	\$0	\$330,250	\$0	\$330,250
2019	\$329,160	\$1,090	\$0	\$330,250	\$0	\$330,250
2018	\$309,490	\$1,090	\$0	\$310,580	\$0	\$310,580
2017	\$296,120	\$1,080	\$0	\$297,200	\$1,773	\$295,427

## Property Deed History

Deed Date	Type	Description	Grantor	Grantee	Volume	Page	Number
9/29/2022	TOD	TRANSFER ON DEATH	STRACKBEIN, KERMIT R	STRACKBEIN, MARIAN G	20226461		

## ARB Data

Hearing Date And Time	Board Members	Owner's Opinion Of Value	Board's Determination Of Value	ARB Determination
-----------------------	---------------	--------------------------	--------------------------------	-------------------

## Estimated Tax Due

If Paid: 02/25/2026 JUL 17

Year	Taxing Jurisdiction	Tax Rate	Market Value	Taxable Value	Base Tax	Base Taxes Paid	Base Tax Due	Discount/Per & Inte
2025	GILLESPIE COUNTY	0.268500	\$466,520	\$466,520	\$622.46	\$622.46	\$0.00	\$
2025	HILL CNTRY UWCD	0.004900	\$466,520	\$466,520	\$22.86	\$22.86	\$0.00	\$
2025	HARPER ISD	0.666900	\$466,520	\$266,520	\$0.00	\$0.00	\$0.00	\$
2025	GILLESPIE WCID	0.000178	\$466,520	\$466,520	\$0.83	\$0.83	\$0.00	\$

# Gillespie CAD Property Search

## Property ID: 8467 For Year 2025

### Property Details

Account		
Property ID:	8467	Geographic ID: A0964-0368-000000-00
Type:	R	Zoning:
Property Use:		Condo:
Location		
Situs Address:	2020 WENDEL RD TX	
Map ID:	5-A	Mapsco:
Legal Description:	ABS A0964 M E P & P RR CO #368, 69.1 ACRES	
Abstract/Subdivision:	A0964	
Neighborhood:	(H200) HARPER NORTH	
Owner		
Owner ID:	349489	
Name:	STRACKBEIN, MARIAN G	
Agent:		
Mailing Address:	2020 WENDEL HARPER, TX 78631	
% Ownership:	100.0%	
Exemptions:	For privacy reasons not all exemptions are shown online.	

### Property Values

Improvement Homesite Value:	\$0 (+)
-----------------------------	---------

<b>Improvement Non-Homesite Value:</b>	\$0 (+)
<b>Land Homesite Value:</b>	\$0 (+)
<b>Land Non-Homesite Value:</b>	\$0 (+)
<b>Agricultural Market Valuation:</b>	\$583,930 (+)
<b>Market Value:</b>	\$583,930 (=)
<b>Agricultural Value Loss:</b>	\$576,060 (-)
<b>Appraised Value:</b>	\$7,870 (=)
<b>HS Cap Loss:</b>	\$0 (-)
<b>Circuit Breaker:</b>	\$0 (-)
<b>Assessed Value:</b>	\$7,870
<b>Ag Use Value:</b>	\$7,870

Information provided for research purposes only, for current ownership research you are able to change the search year to 2026. Legal descriptions and acreage amounts are for Appraisal District use only and should be verified prior to using for legal purpose and or documents. Please contact the Appraisal District to verify all information for accuracy.

## Property Taxing Jurisdiction

**Owner:** STRACKBEIN, MARIAN G

Entity	Description	Market Value	Taxable Value	Estimated Tax	Freeze Ceiling
G086	GILLESPIE COUNTY	\$583,930	\$7,870	\$21.13	
HUW	HILL CNTRY UWCD	\$583,930	\$7,870	\$0.39	
SHP	HARPER ISD	\$583,930	\$7,870	\$52.49	
WCD	GILLESPIE WCID	\$583,930	\$7,870	\$0.01	

CAD	GILLESPIE CENTRAL APPRAISAL DISTRICT	\$583,930	\$7,870	\$0.00	
-----	--------------------------------------	-----------	---------	--------	--

**Total Tax Rate:** 0.940478

**Estimated Taxes With Exemptions:** \$74.02

**Estimated Taxes Without Exemptions:** \$5,491.73

## Property Improvement - Building

## Property Land

Type	Description	Acreage	Sqft	Eff Front	Eff Depth	Market Value	Prod. Value
RN1	NATIVE PASTURE 1	28.10	1,224,036.00	0.00	0.00	\$237,460	\$3,300
RN2	NATIVE PASTURE 2	38.00	1,655,280.00	0.00	0.00	\$321,120	\$4,250
RN3	NATIVE PASTURE 3	3.00	130,680.00	0.00	0.00	\$25,350	\$320

## Property Roll Value History

Year	Improvements	Land Market	Ag Valuation	Appraised	HS Cap Loss	Assessed
2025	\$0	\$583,930	\$7,870	\$7,870	\$0	\$7,870
2024	\$0	\$583,930	\$7,300	\$7,300	\$0	\$7,300
2023	\$0	\$583,930	\$7,300	\$7,300	\$0	\$7,300
2022	\$0	\$518,250	\$6,800	\$6,800	\$0	\$6,800
2021	\$0	\$345,500	\$6,730	\$6,730	\$0	\$6,730
2020	\$0	\$302,380	\$5,320	\$5,320	\$0	\$5,320
2019	\$0	\$302,380	\$5,320	\$5,320	\$0	\$5,320
2018	\$0	\$302,380	\$5,030	\$5,030	\$0	\$5,030
2017	\$0	\$298,900	\$4,950	\$4,950	\$0	\$4,950

## Property Deed History

Deed Date	Type	Description	Grantor	Grantee	Volume	Page	Number
9/29/2022	TOD	TRANSFER ON DEATH	STRACKBEIN, KERMIT R	STRACKBEIN, MARIAN G	20226461		

## ARB Data

Hearing Date And Time	Board Members	Owner's Opinion Of Value	Board's Determination Of Value	ARB Determination

## Estimated Tax Due

If Paid:

03/04/2026



Year	Taxing Jurisdiction	Tax Rate	Market Value	Taxable Value	Base Tax	Base Taxes Paid	Base Tax Due	Discount/Penalty & Interest
2025	GILLESPIE COUNTY	0.268500	\$583,930	\$7,870	\$21.13	\$21.13	\$0.00	\$0.00
2025	HILL CENTRY UWCD	0.004900	\$583,930	\$7,870	\$0.39	\$0.39	\$0.00	\$0.00
2025	HARPER ISD	0.666900	\$583,930	\$7,870	\$52.49	\$52.49	\$0.00	\$0.00
2025	GILLESPIE WCID	0.000178	\$583,930	\$7,870	\$0.01	\$0.01	\$0.00	\$0.00
	2025 Total:	0.940478			\$74.02	\$74.02	\$0.00	\$0.00
2024	GILLESPIE COUNTY	0.268500	\$583,930	\$7,300	\$19.60	\$19.60	\$0.00	\$0.00
2024	HILL CENTRY UWCD	0.004800	\$583,930	\$7,300	\$0.35	\$0.35	\$0.00	\$0.00